

HSP / HSM heat sink

- Acid prevention by exterior handling
- Various specs of standard radiator
- Manufacturing SSR accuracy TAP
- DIN rail structure installation method (HSP Series)

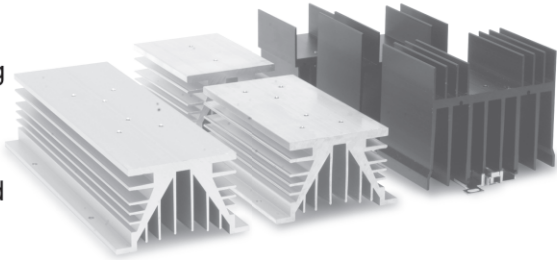

■ HSP Series (Unit : mm)

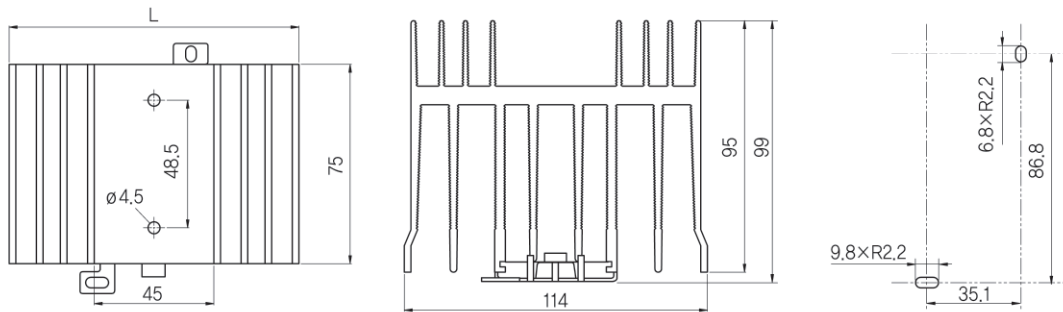

Model	Applying models	Capacity(A)	Length(L)
HSP-10	HSR-2□10□□	10(A)	48 mm
HSP-20	HSR-2□20□□	20(A)	80 mm
HSP-40	HSR-2□30□□	30(A)	109 mm
	HSR-2□40□□	40(A)	

■ HSM Series (Unit : mm)

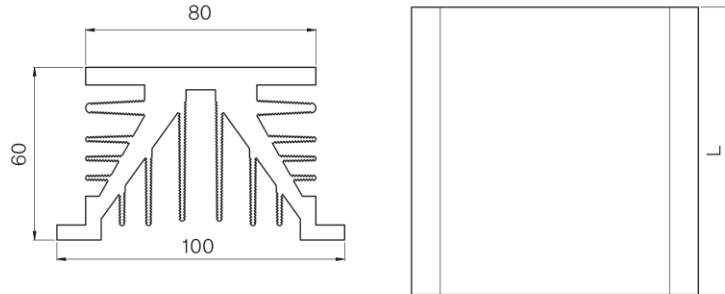

Model	Applying models	Capacity(A)	Length(L)
HSM-70	HSR-2□10□□	10(A)	70 mm
HSM-110	HSR-2□20□□	20(A)	110 mm
	HSR-2□30□□	30(A)	
HSM-150	HSR-2□40□□	40(A)	150 mm
	HSR-3□10□□	10(A)	
HSM-200	HSR-3□20□□	20(A)	200 mm
	HSR-3□30□□	30(A)	
HSM-250	HSR-3□40□□	40(A)	250 mm

■ Things to consider when using the HEAT SINK

- Even though when using the standard heat sink, if ambient temperature increases or if there is no ventilation, it may damage the SSR so please be cautious.
- Normally SSR is damaged when max temperature is above 125 and when heat sink temperature is above 80, SSR temperature is close to 125 so must measure the temperature of heat sink during operation
- When installing SSR to the standard heat sink, please use the thermal conductivity grease and etc in order to make the thermal contact smooth.
- Please strongly tighten the bolt so it will not get influenced from the vibration
- Please do not use it with the thermal resistive materials (wooden platter, plastic, rubber). Please use the standard heat sink to glue the heat resistance grease on the contact part and attach it.